



## Construction d'un village d'activité

4, rue du Hoguet 35 000 RENNES

# PLANS DE VENTE





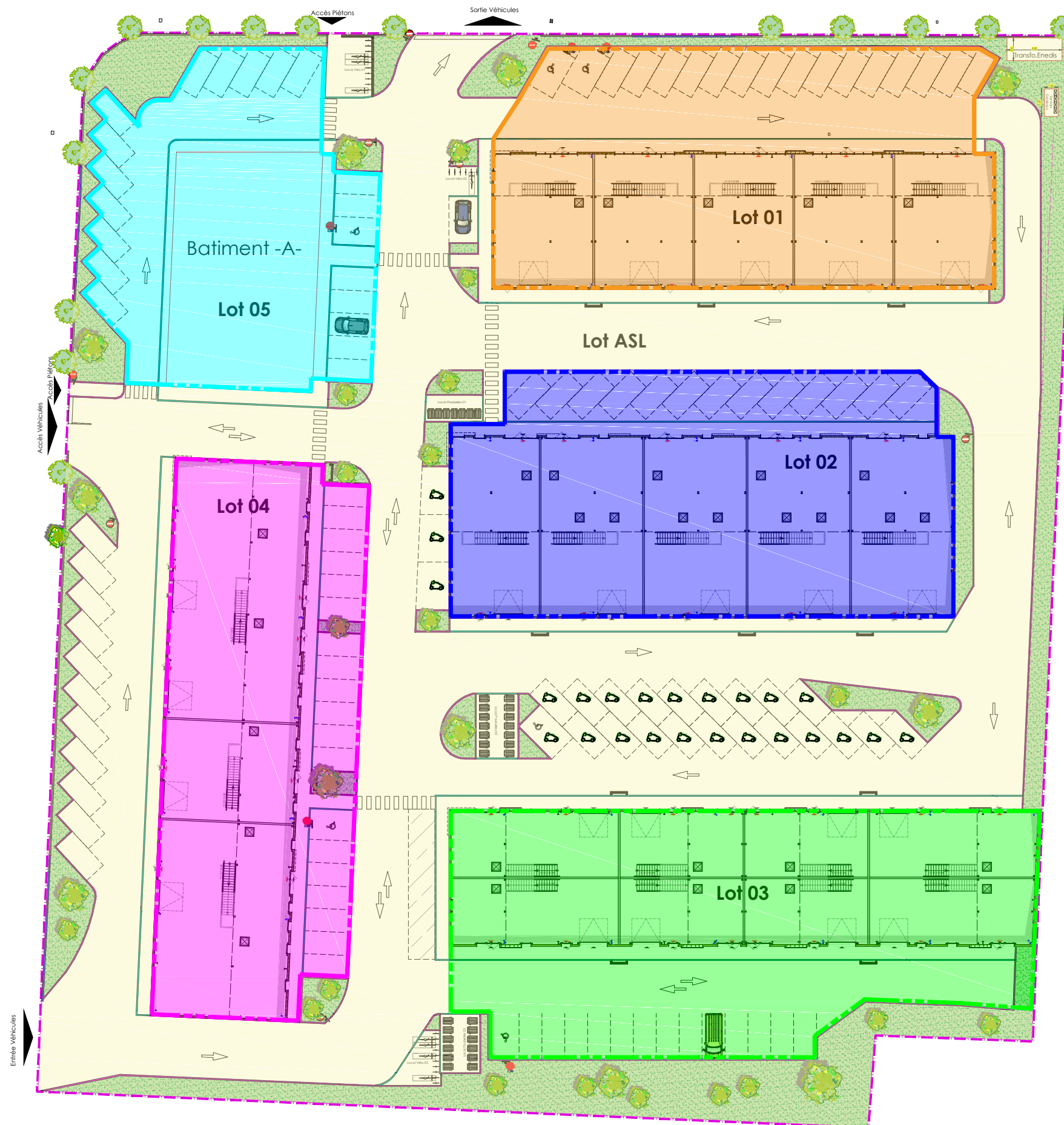

- Lot ASL :5805 m<sup>2</sup>
- Lot 01 : 1411 m<sup>2</sup>
- Lot 02 : 1451 m<sup>2</sup>
- Lot 03 : 1599 m<sup>2</sup>
- Lot 04 : 1280 m<sup>2</sup>
- Lot 05 : 996 m<sup>2</sup>

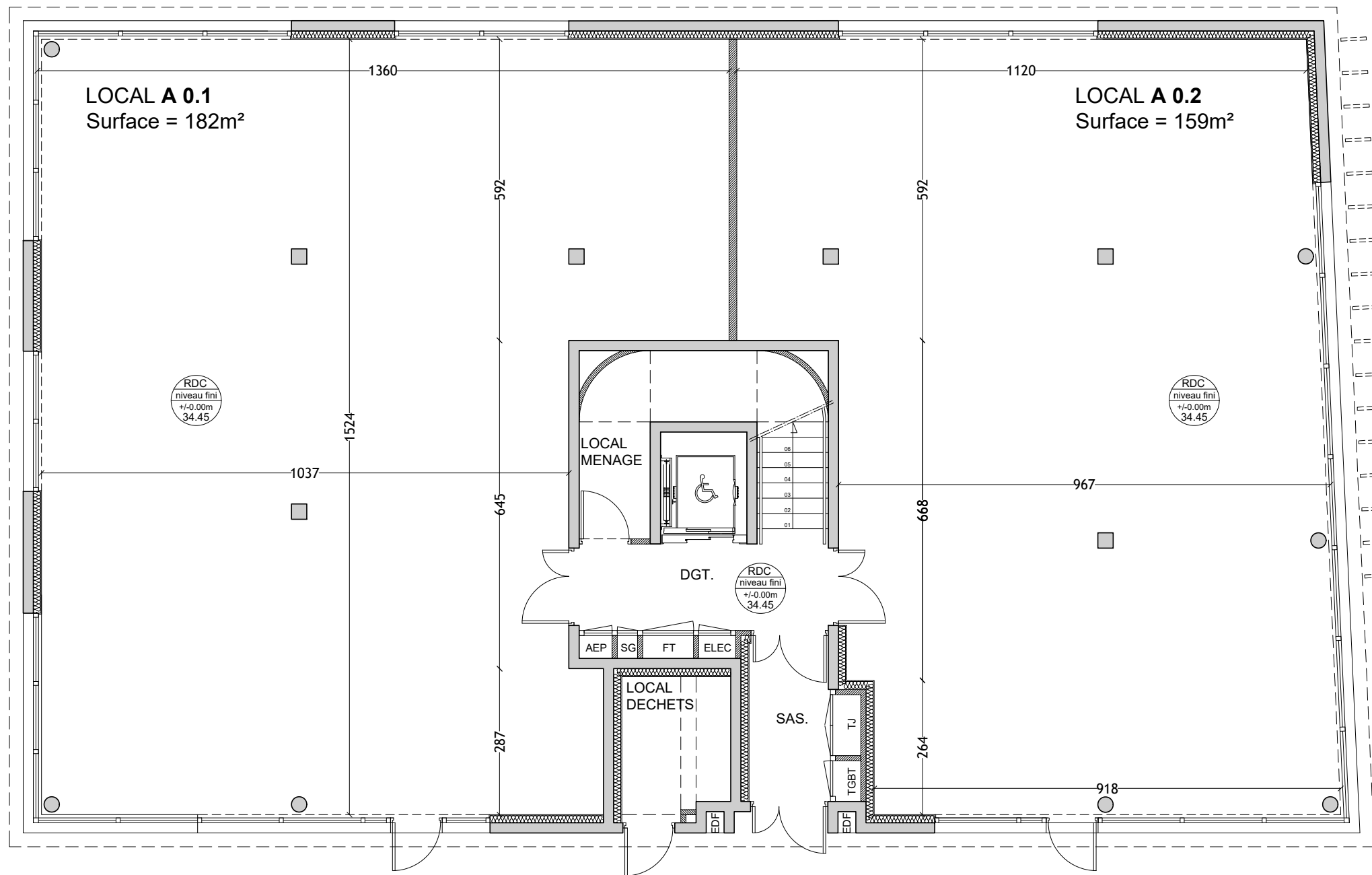

PLAN DU REZ-DE-CHAUSSEE

TABLEAU DE SURFACES :

	Surface
LOCAL A 0.1	182
LOCAL A 1.2	159
DGT.	11
SAS	6
L. MENAGE	6
L. DECHETS	-
<b>TOTAL</b>	<b>364m²</b>

Ces plans sont réservés exclusivement à un usage commercial

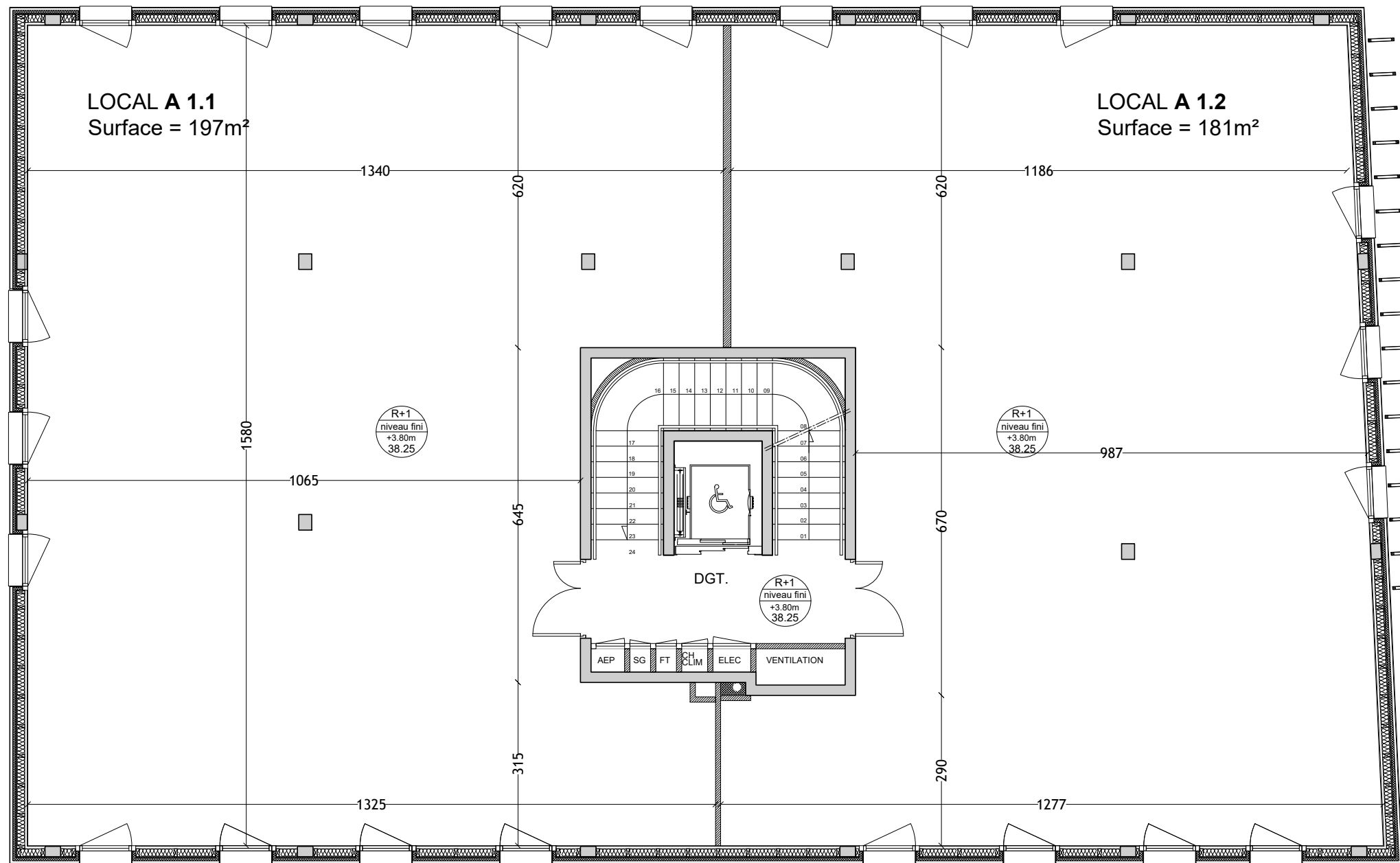

PLAN DU NIVEAU 1

TABLEAU DE SURFACES :

	Surface
LOCAL A 1.1	197
LOCAL A 1.2	181
DGT.	11
<b>TOTAL</b>	<b>389m<sup>2</sup></b>

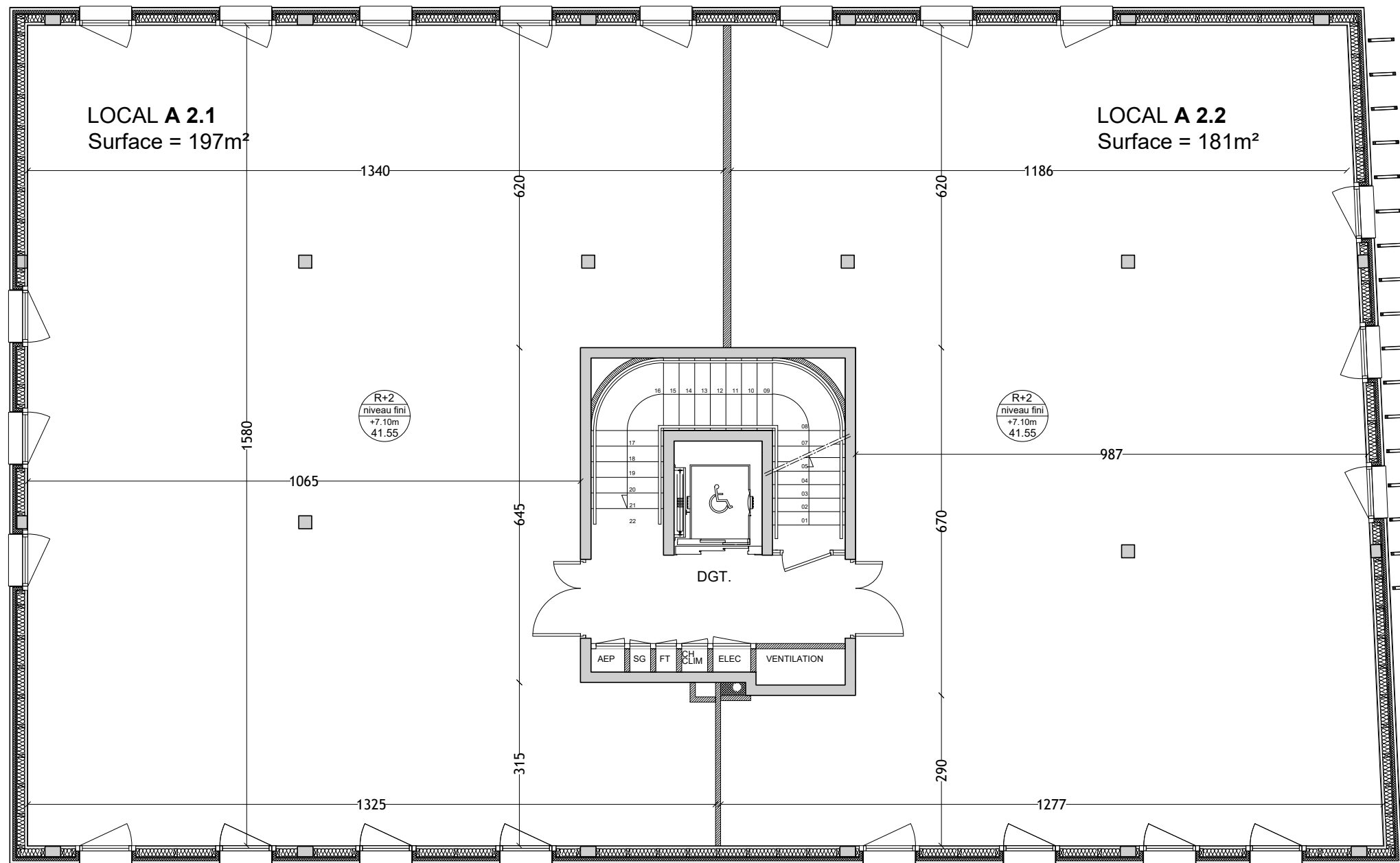

PLAN DU NIVEAU 2

TABLEAU DE SURFACES :

	Surface
LOCAL A 2.1	197
LOCAL A 2.2	181
DGT.	12
<b>TOTAL</b>	<b>390m<sup>2</sup></b>

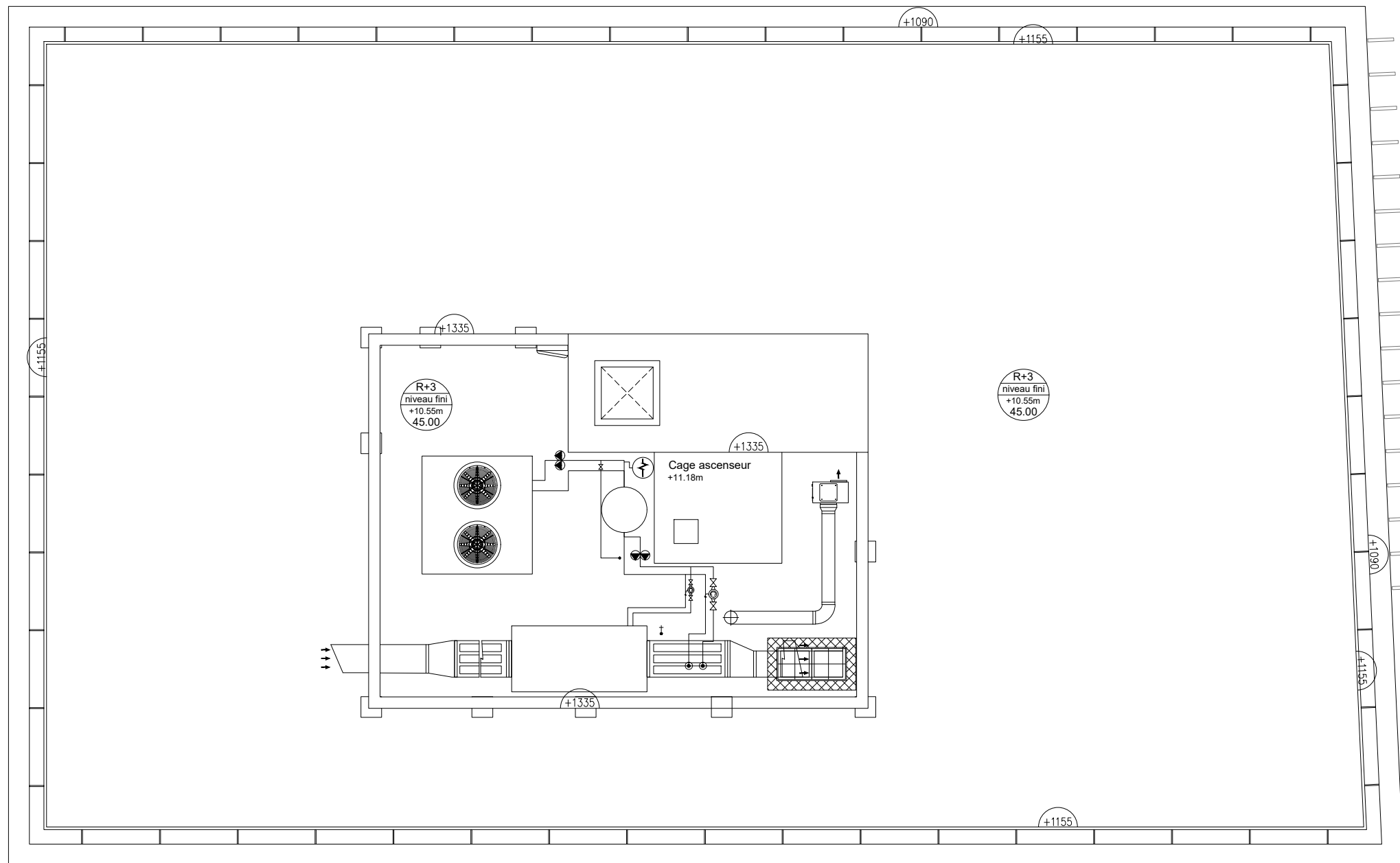

PLAN DE LA TOITURE



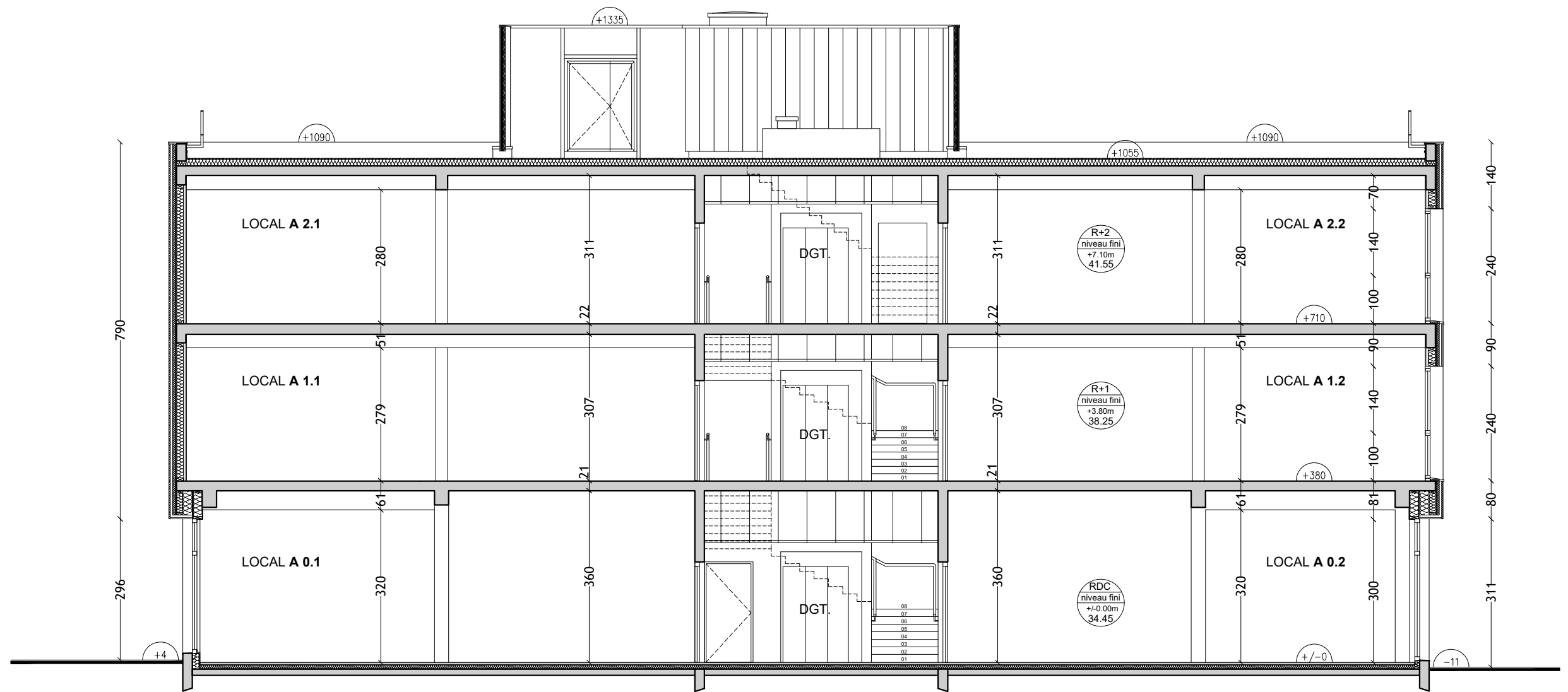

COUPE TRANSVERSALE

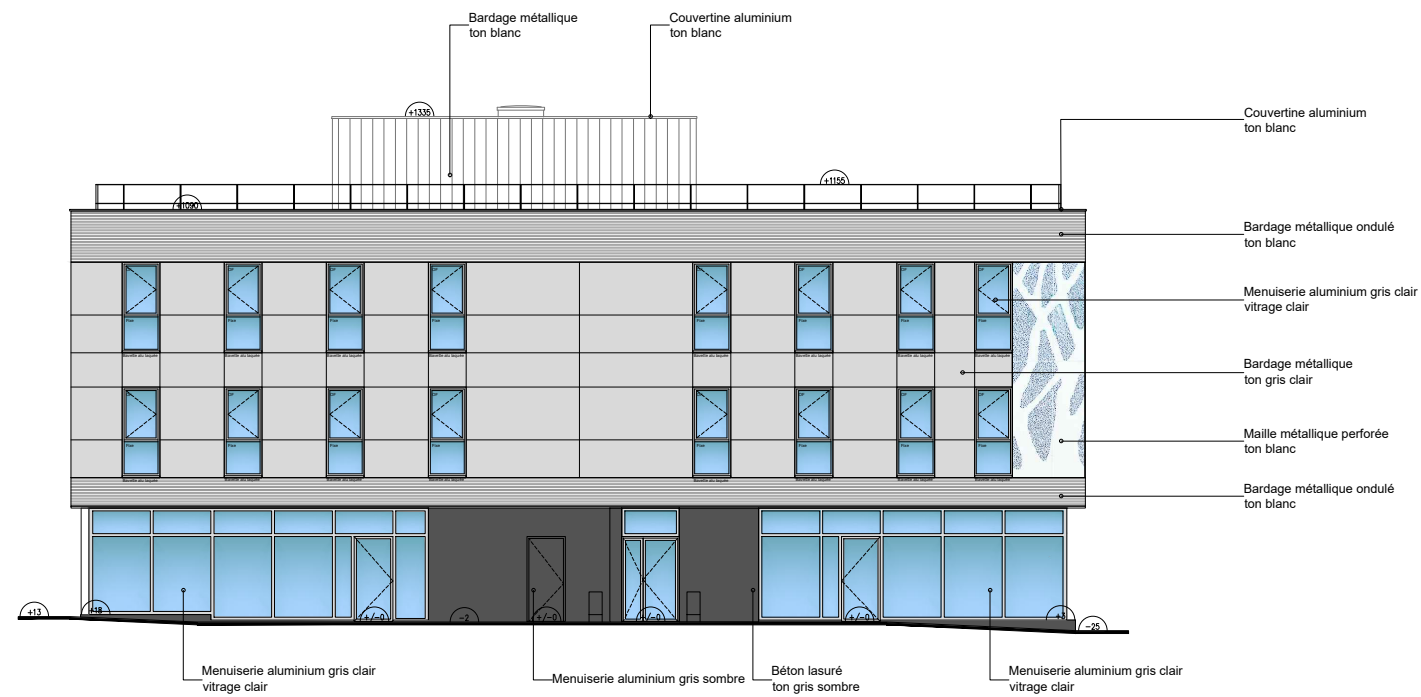

FACADE SUD EST

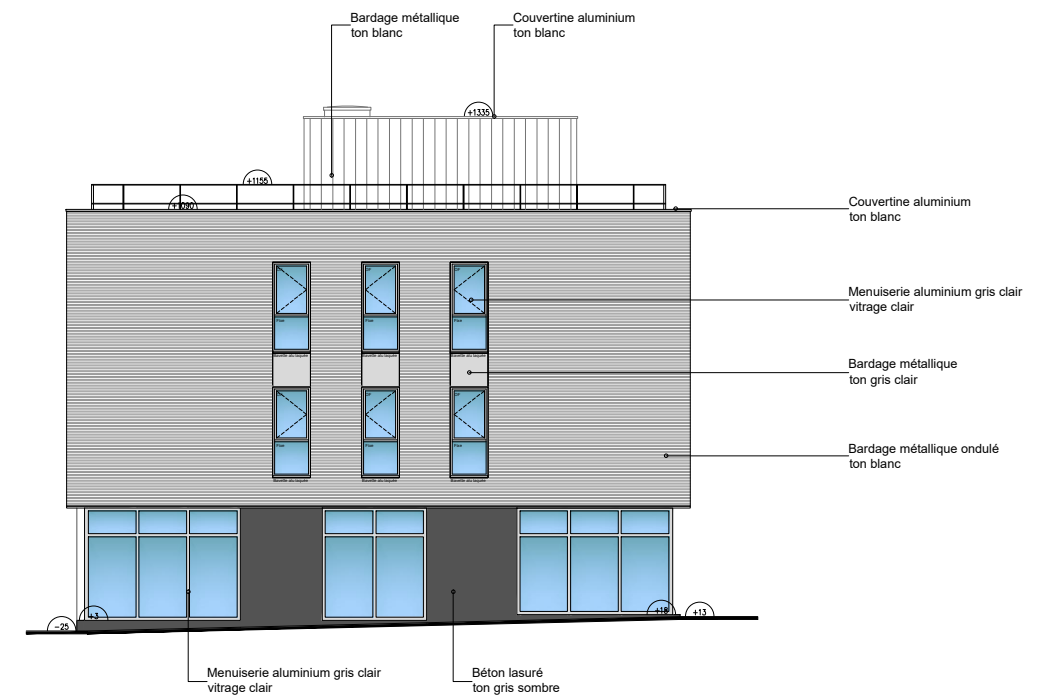

FACADE SUD OUEST

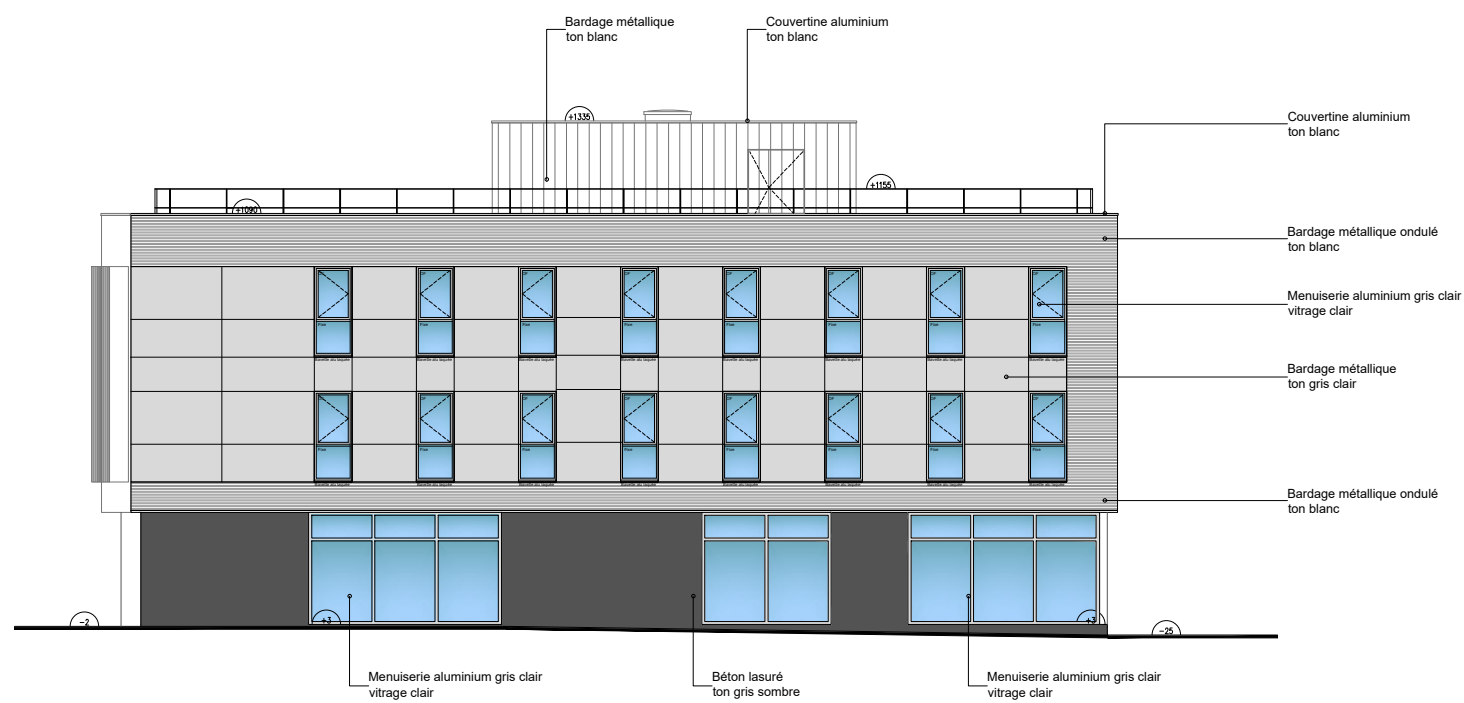

FACADE SUD EST

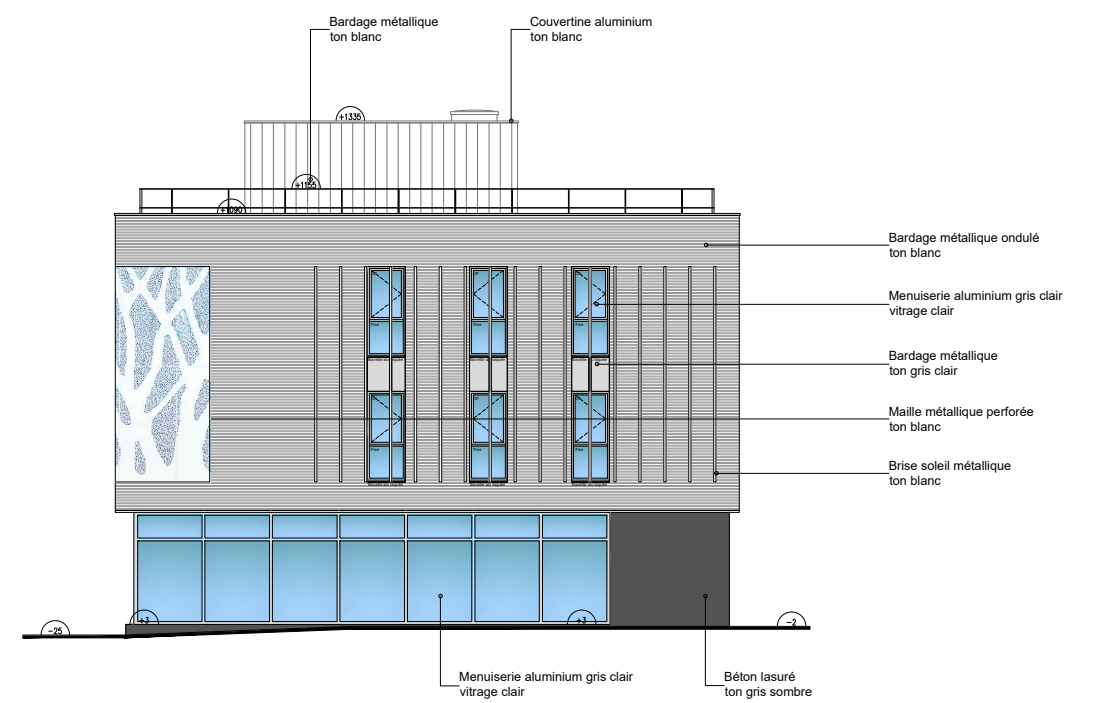

FACADE NORD EST





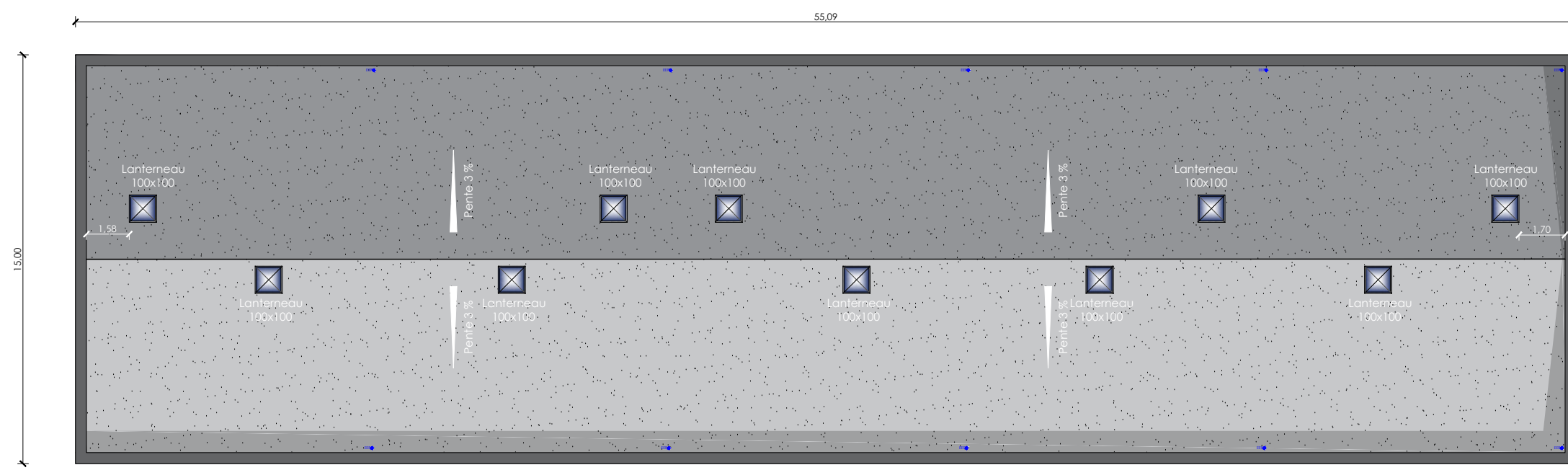

-Toiture-



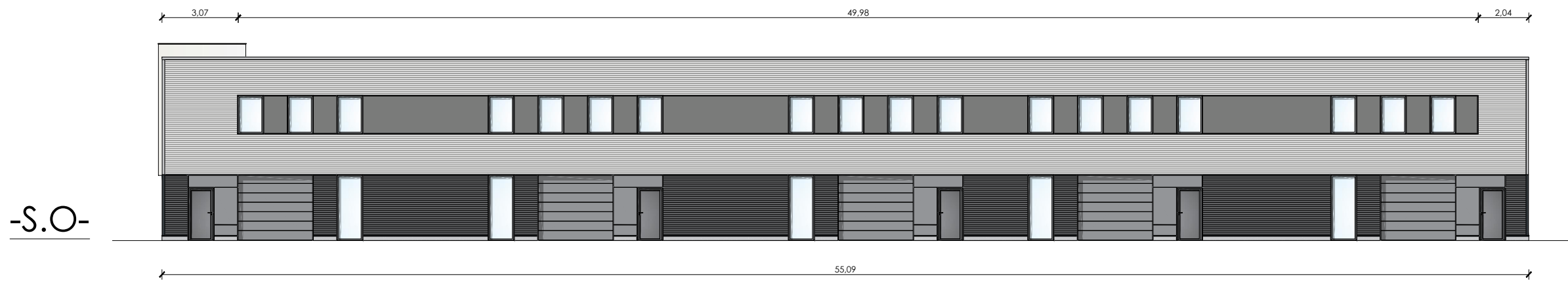
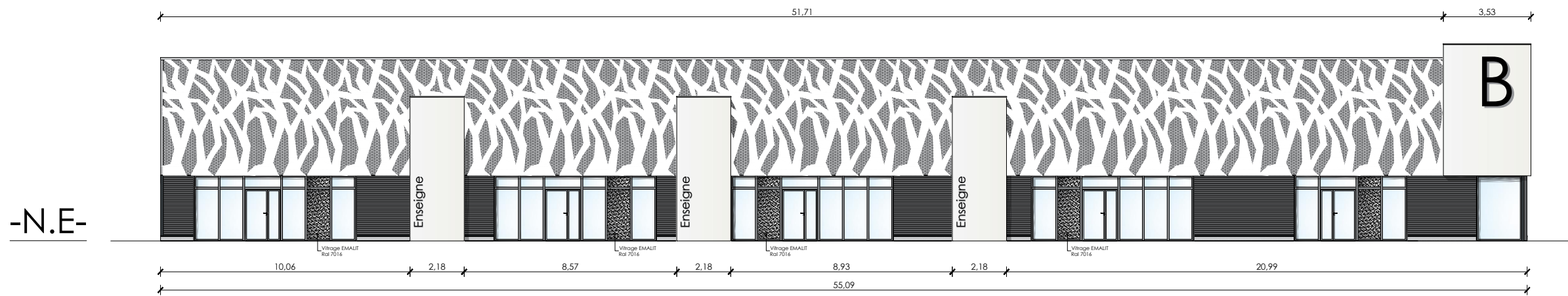
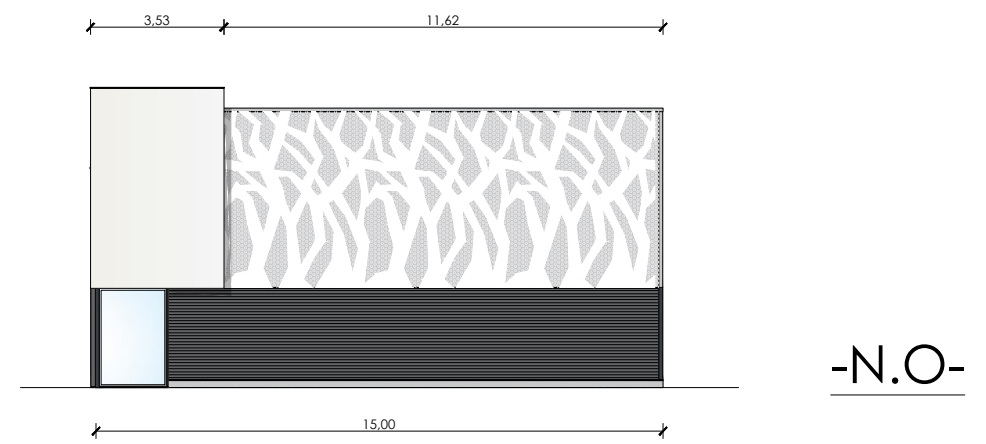
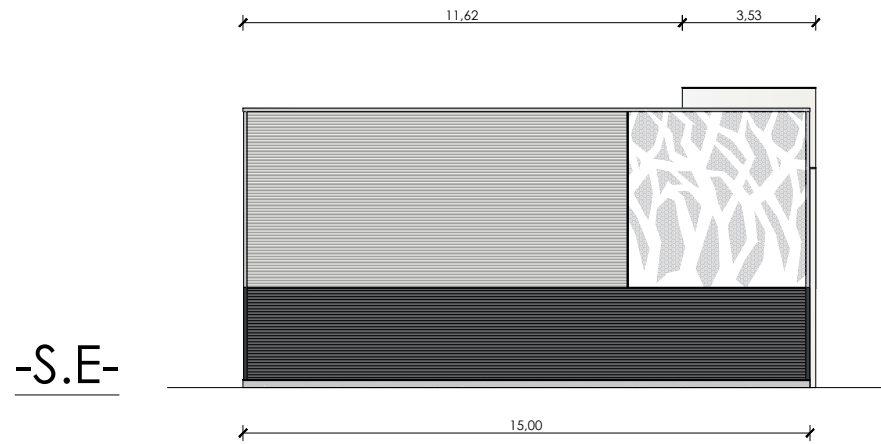

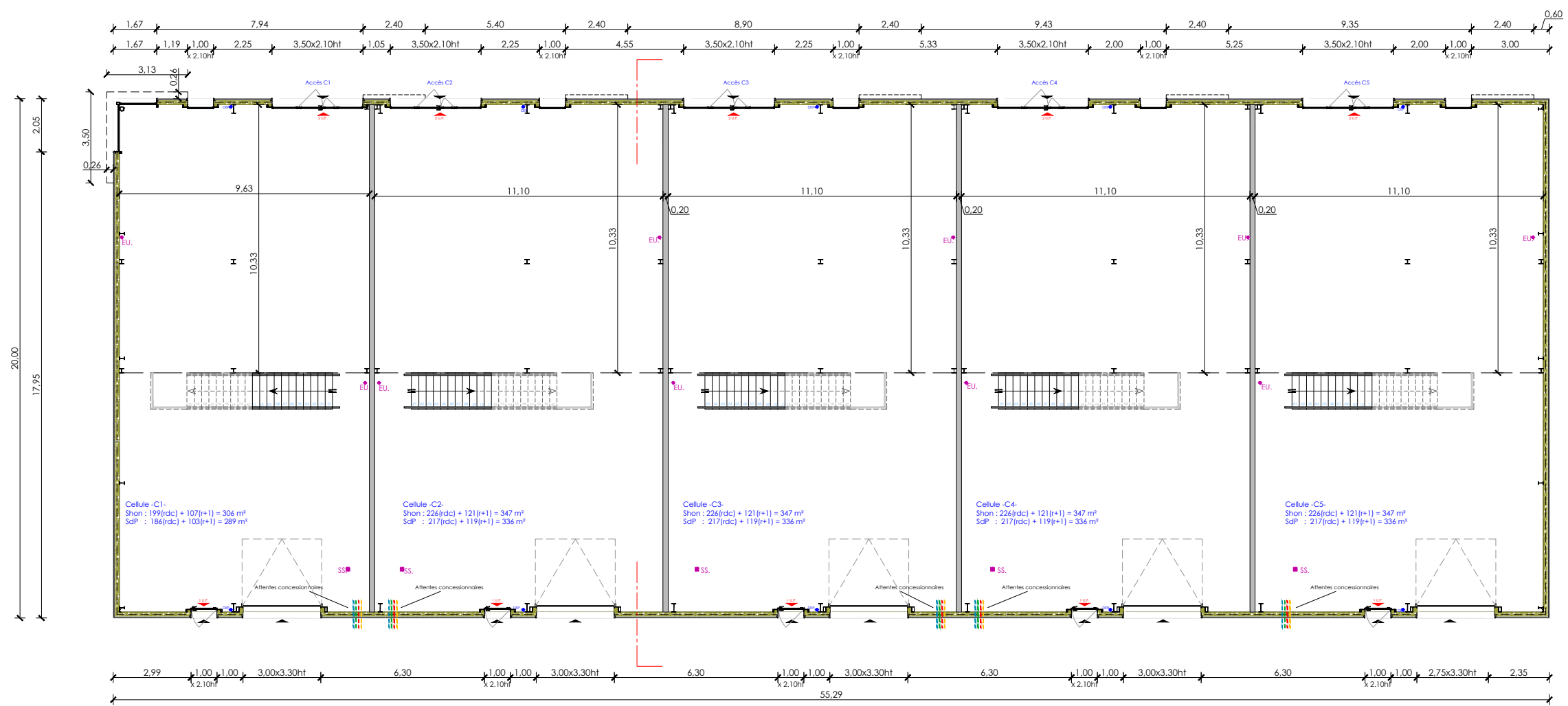
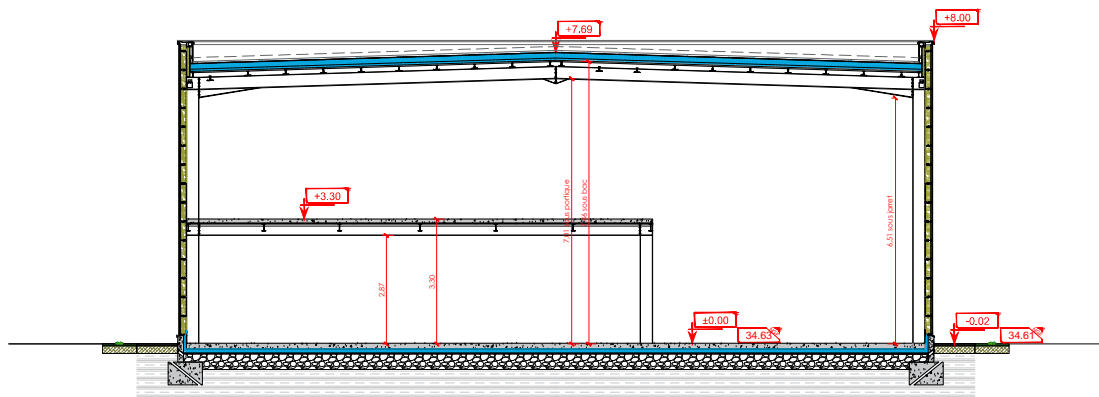

-RDC-

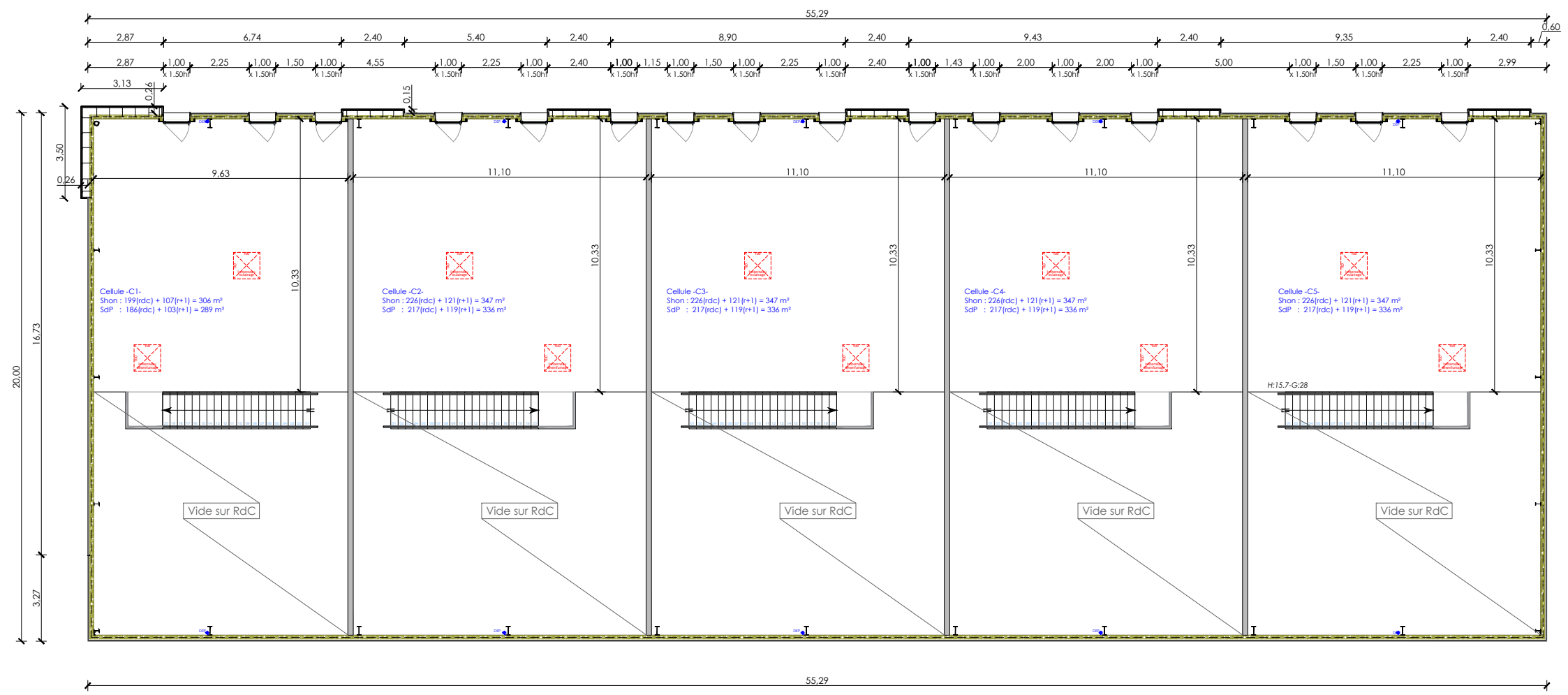

-R+1-





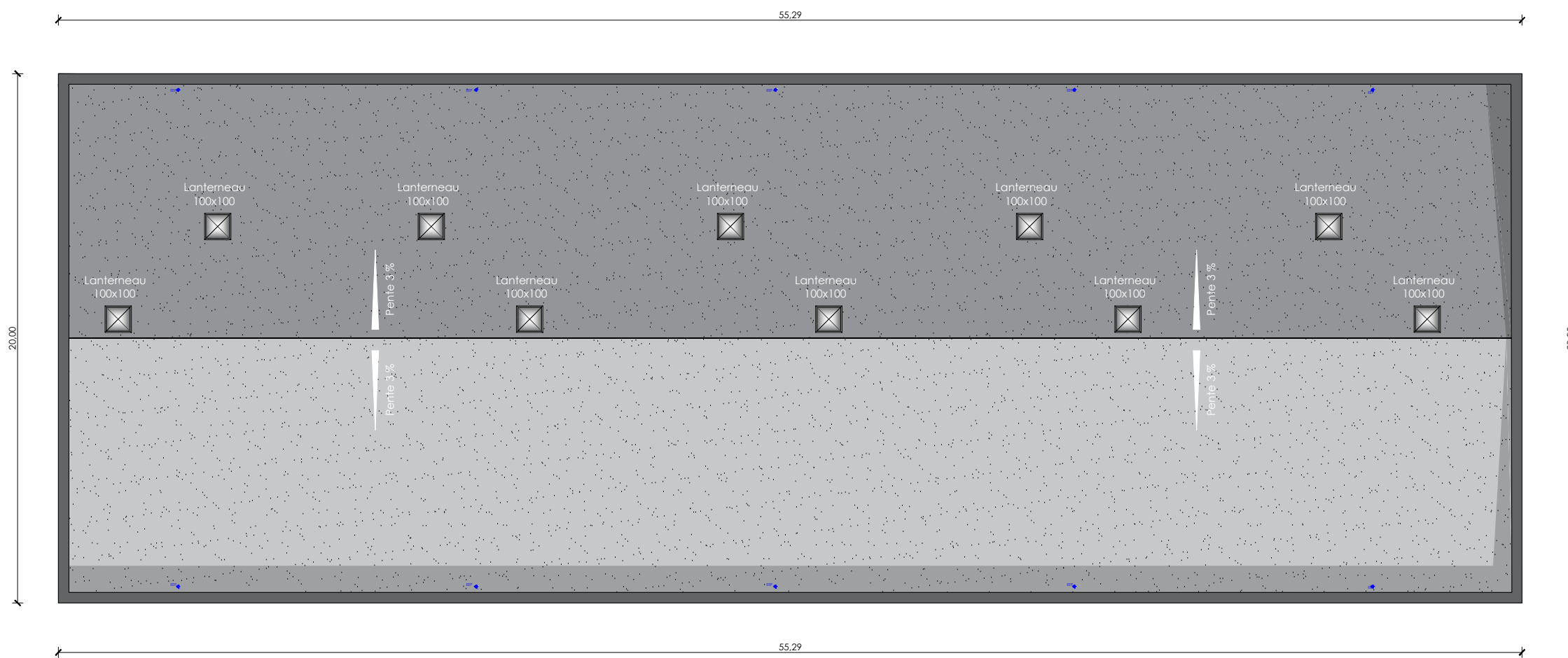

-Toiture-

-S.E-

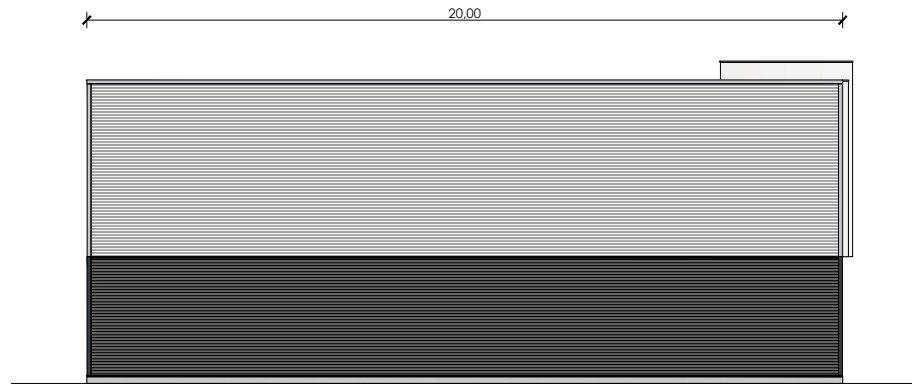

-N.O-

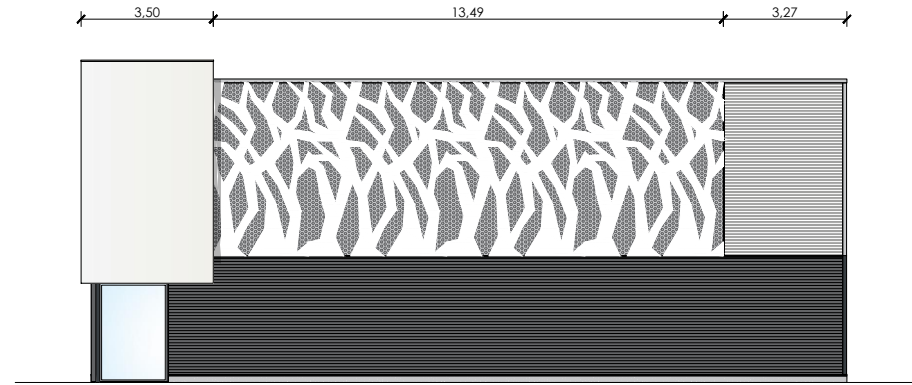

-N.E-



-S.O-

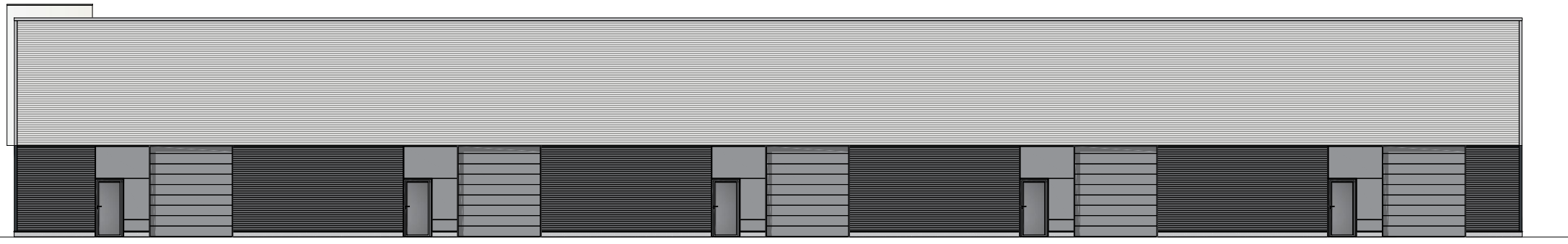

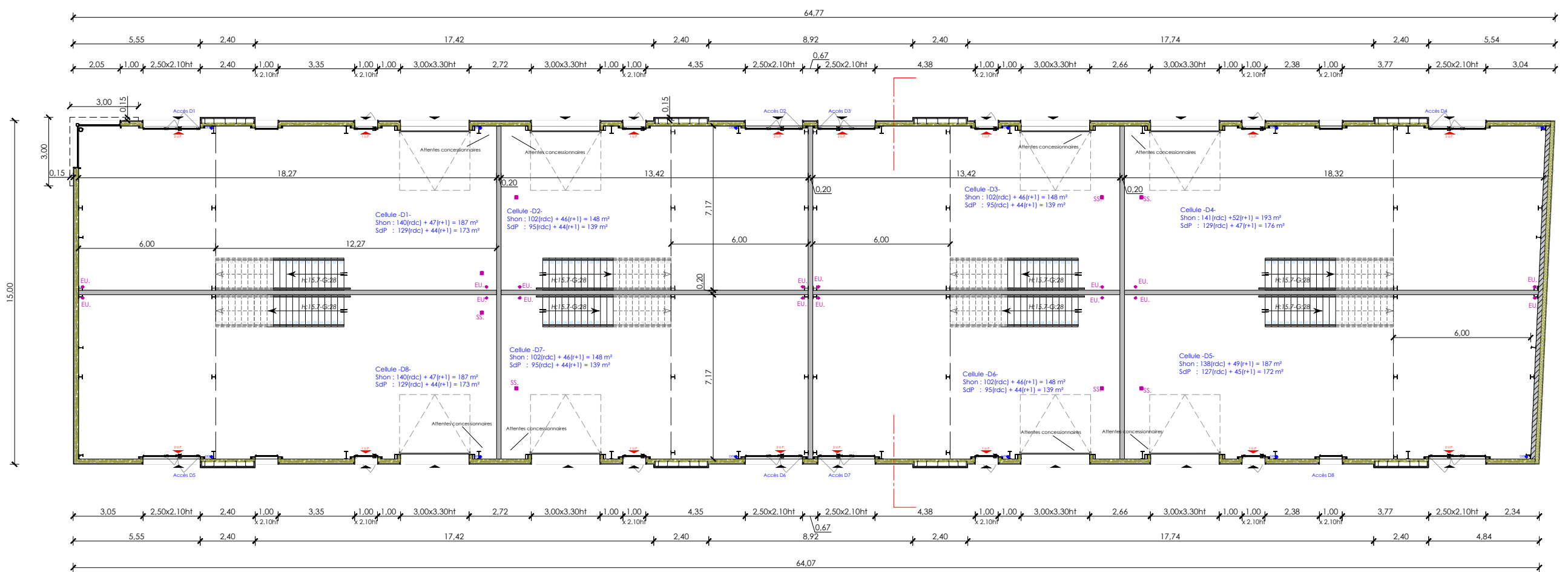
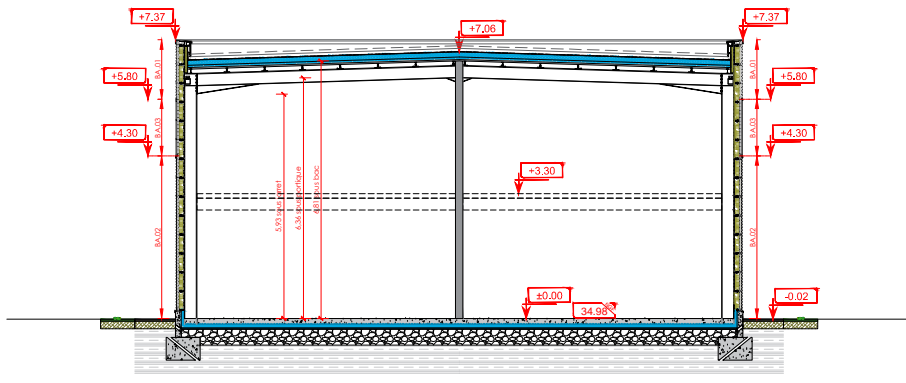

-RDC-



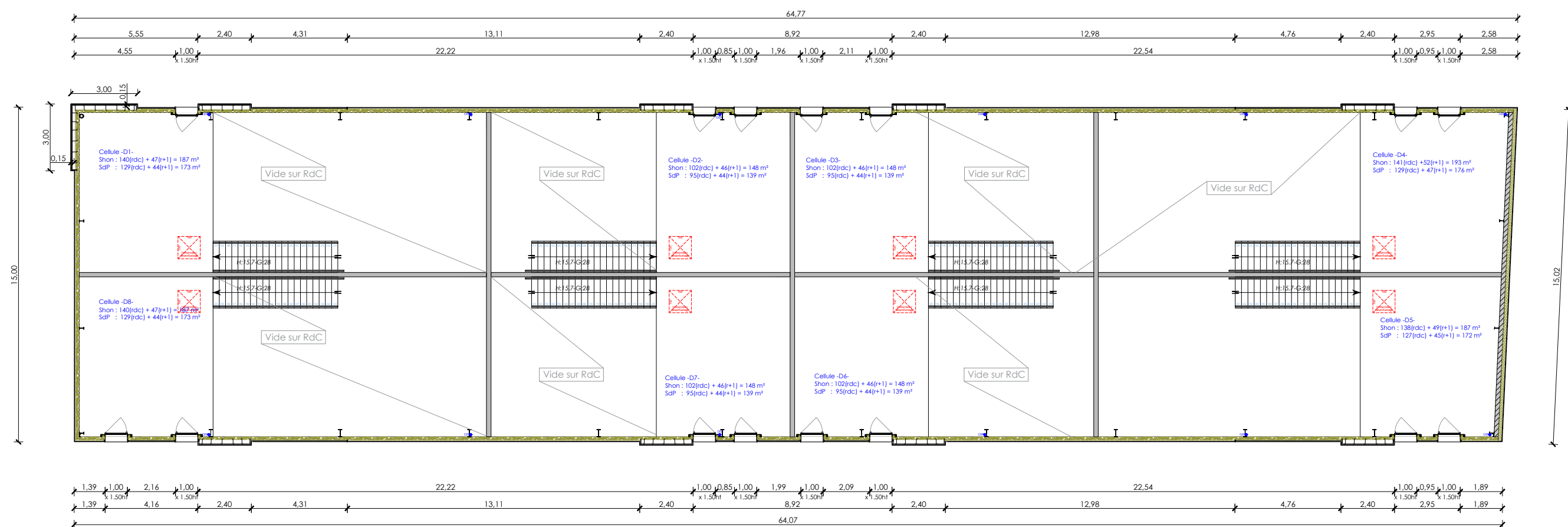

-R+1-

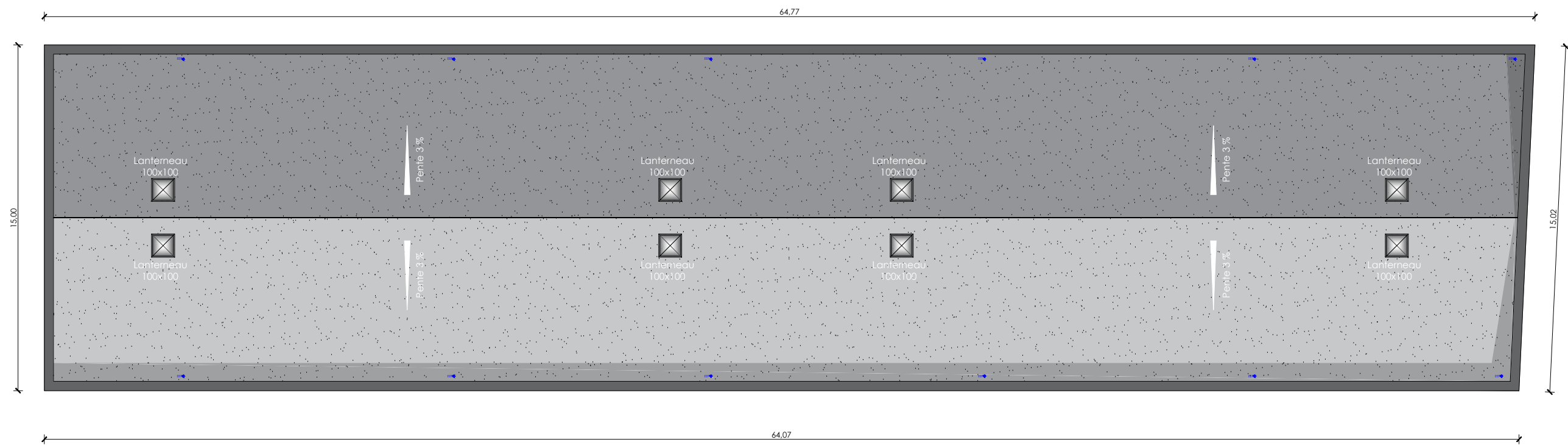

-Toiture-

-S.E-

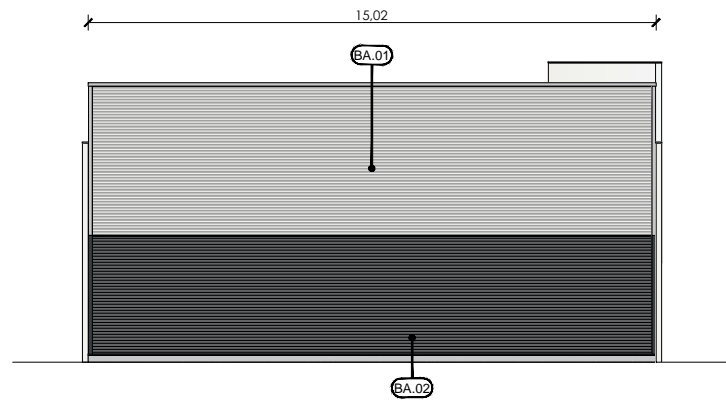

-N.O-

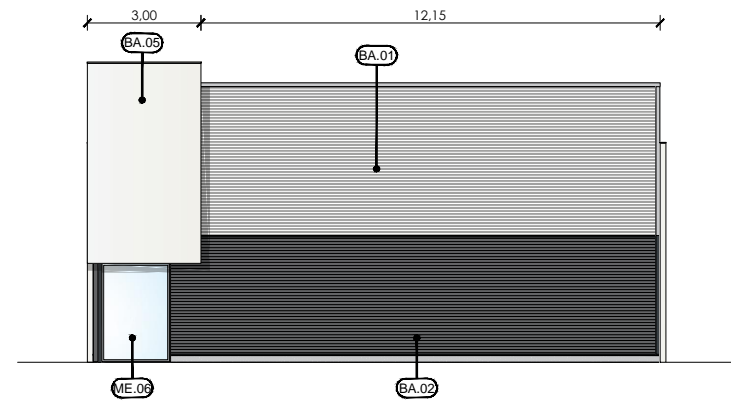

-N.E-

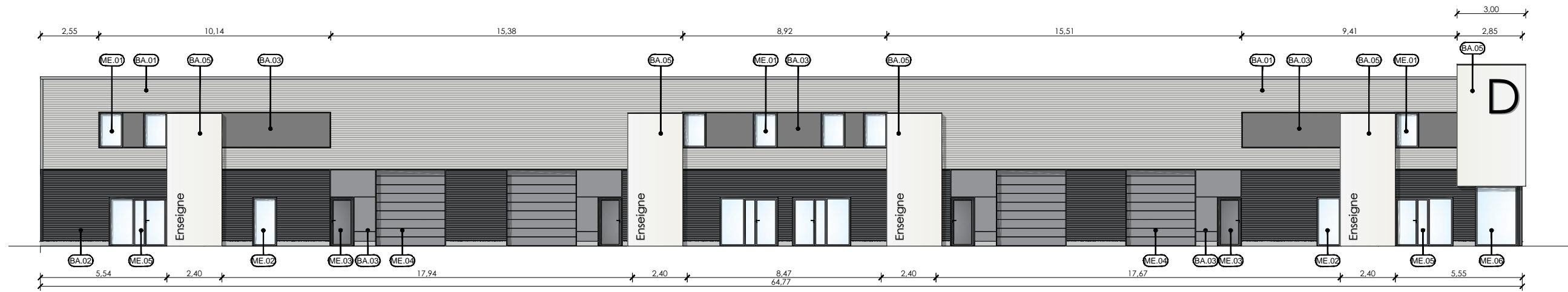

-S.O-

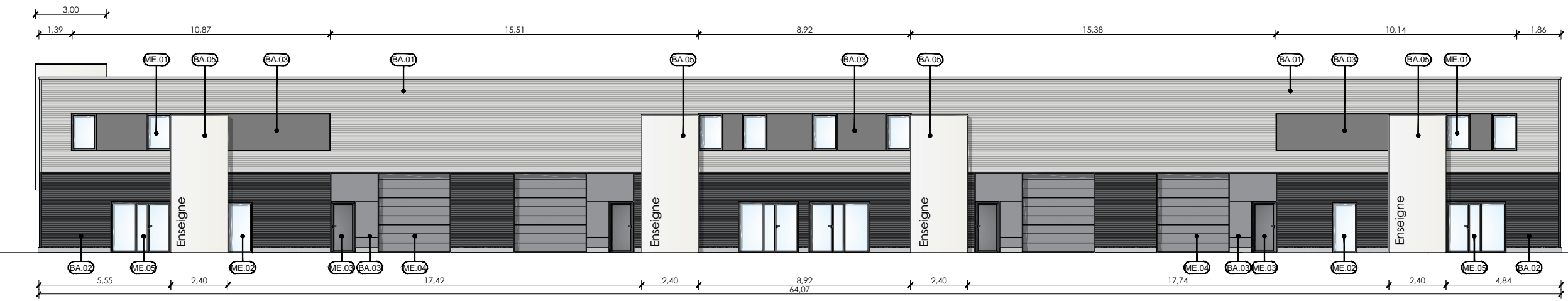

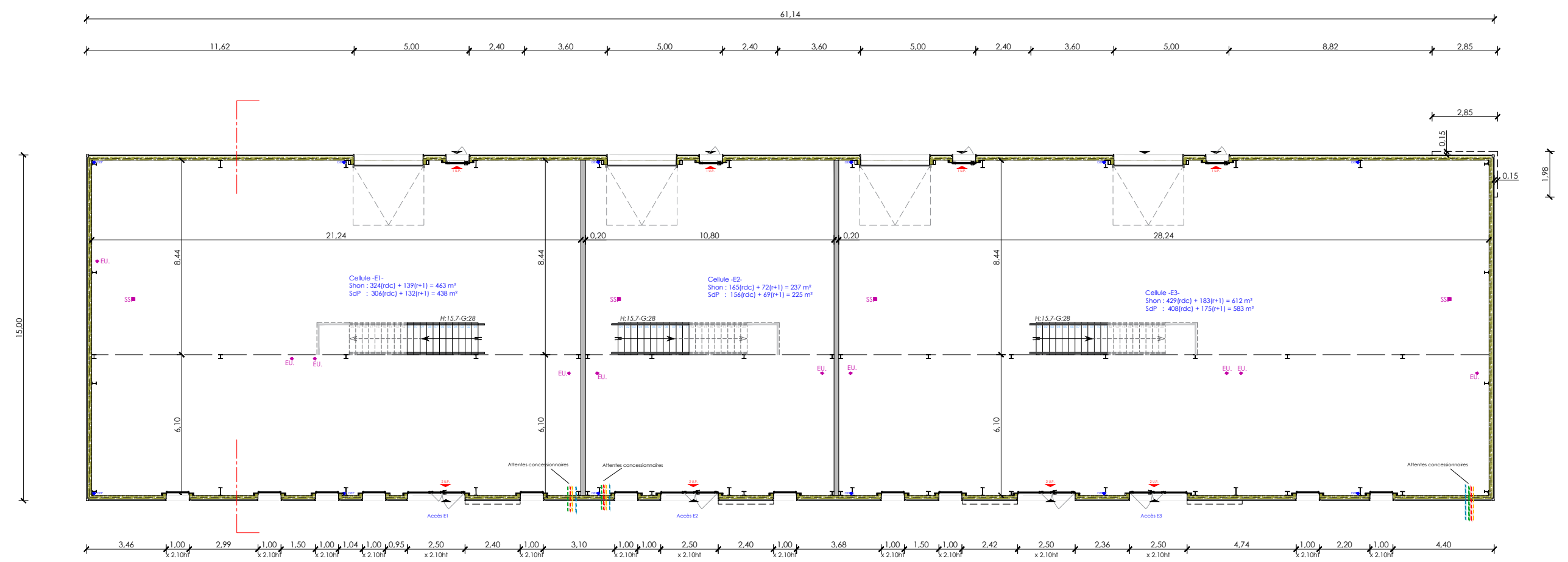
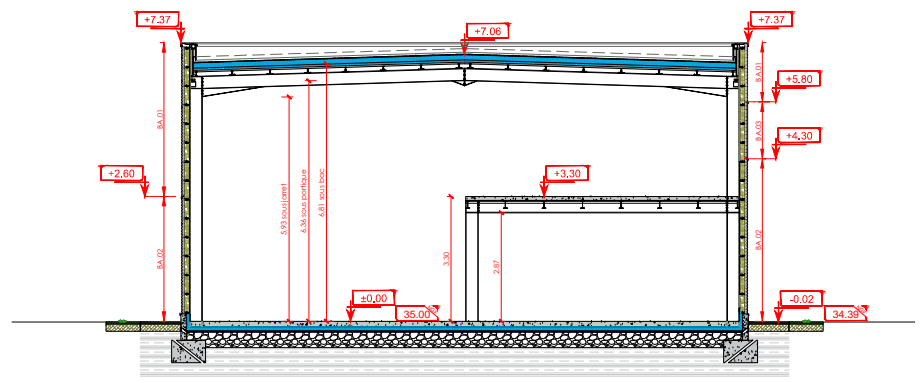

-RDC-



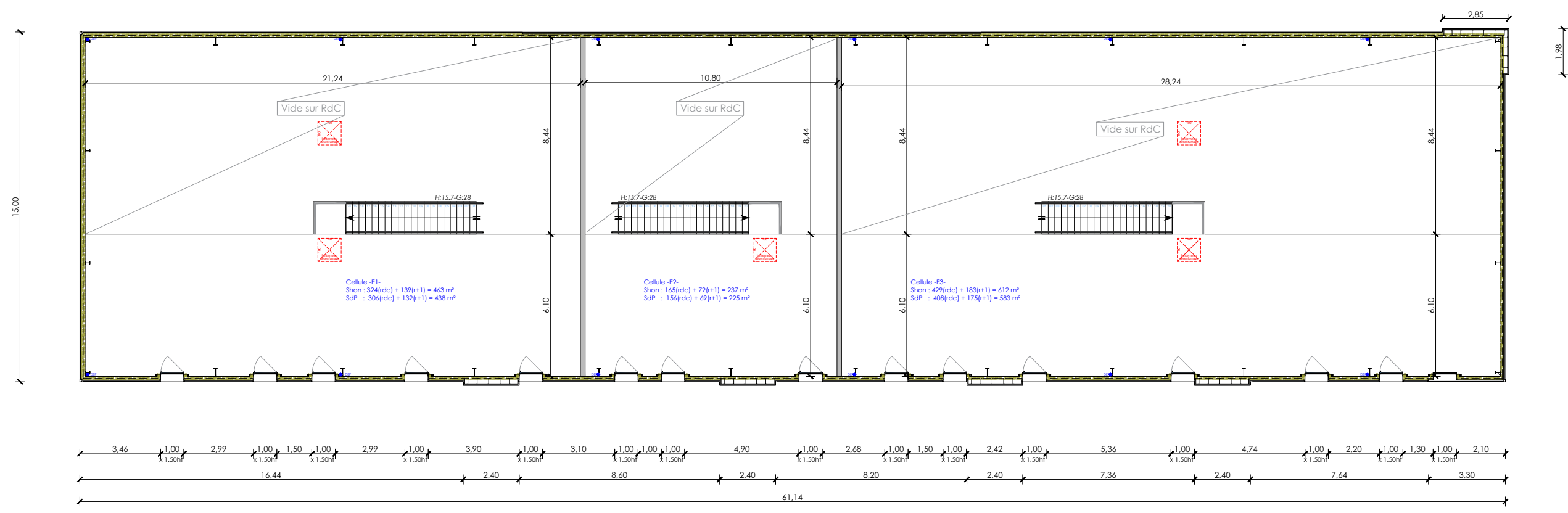

-R+1-





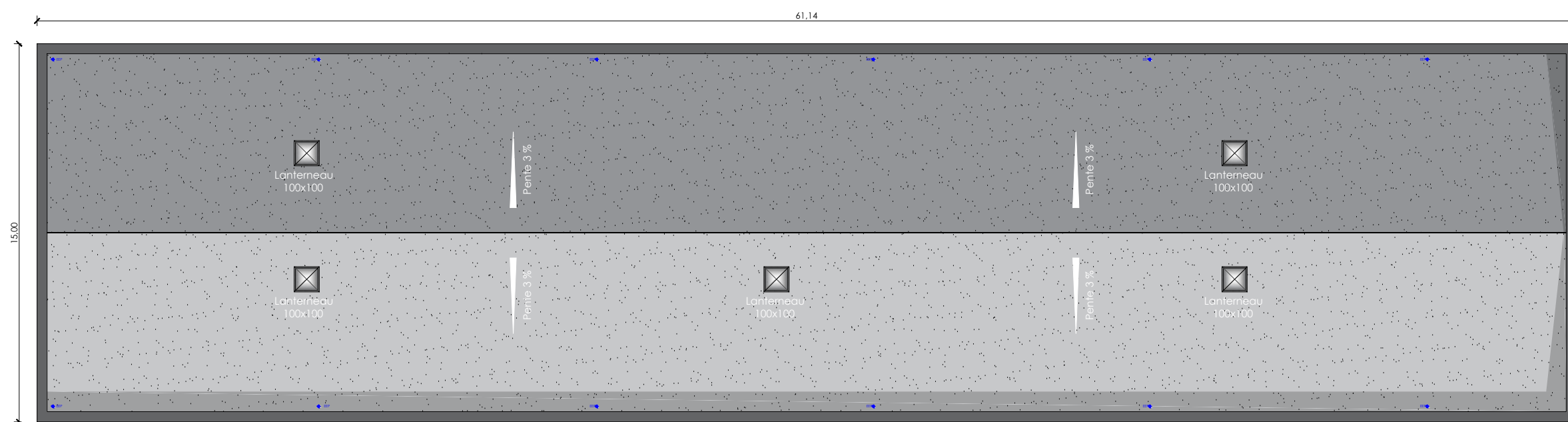

-Toiture-

-S.O-

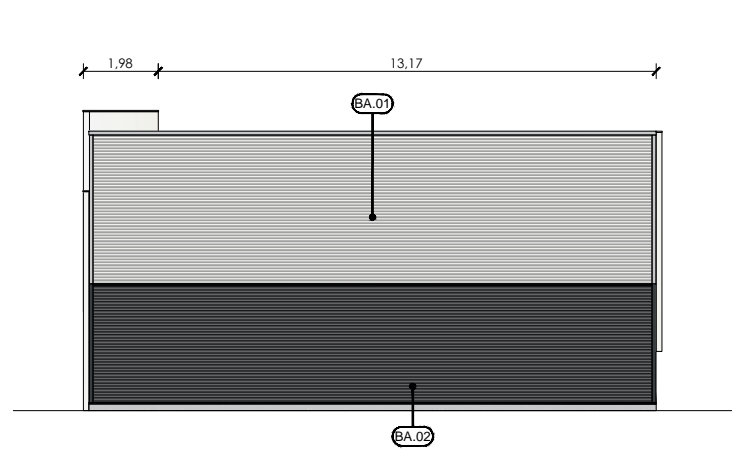

-N.E-

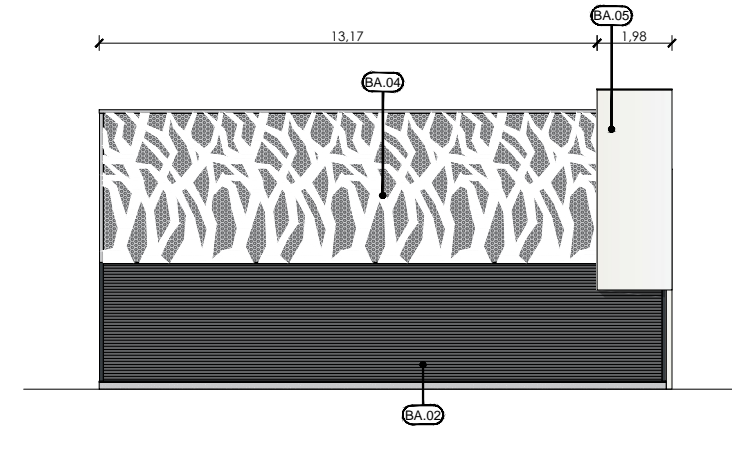

-S.E-

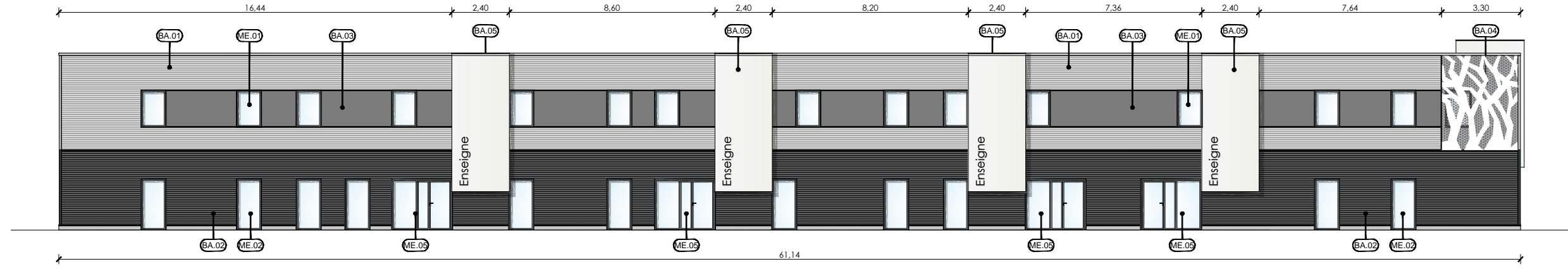

-N.O-

